

Super Tuna][+ Schematic

W5USJ drawing 12 Feb 2017

Band Module — H1/H2 viewed from the top of the board

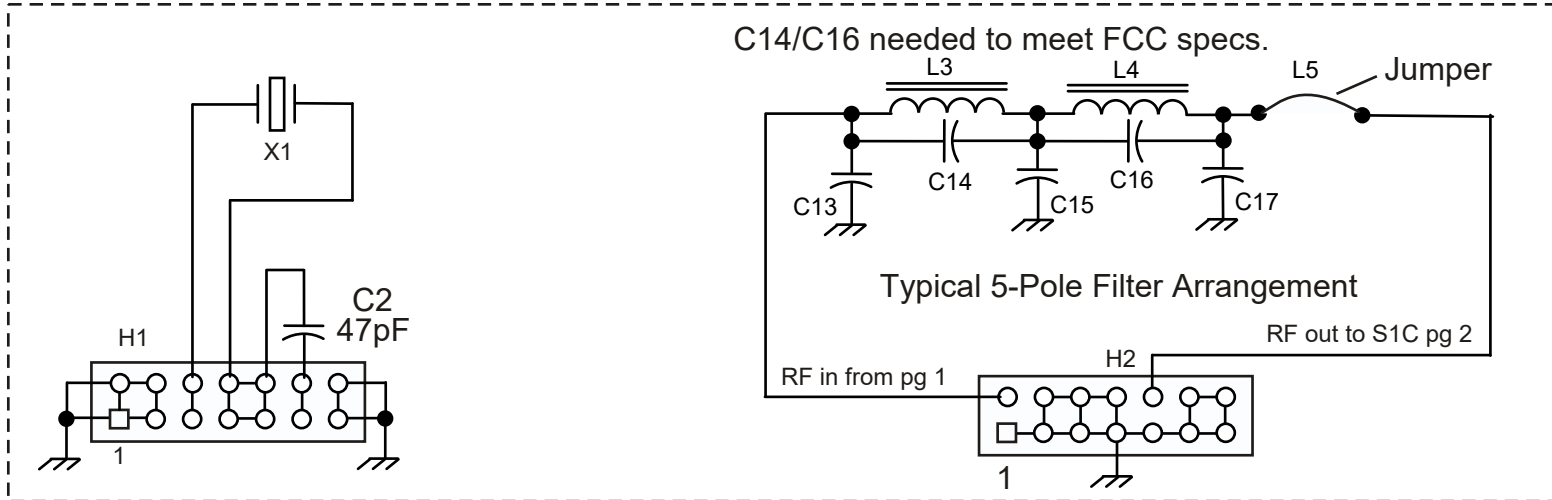

5-Pole Filters: All capacitors pF, Kemet 5% C0G or equiv.

80 C13, 680 C14, 100 C15, 1200 C16, 220 C17, 680
L3/L4, 2.2uH 21t #22 T50-2 or 23t #24 T37-2

40 C13, 330 C14, 47 C15, 680 C16, 150 C17, 330
L3, 1.2uH 15t #22 T50-2 or 17t #24 T37-2
L4, 0.85uH 13t #22 T50-2 or 15t #24 T37-2

30 C13, 220 C14, 47 C15, 470 C16, 82 C17, 220
L3, 1.0uH 14t #22 T50-2 or 16t #24 T37-2
L4, 0.75uH 12t #22 T50-2 or 14t #24 T37-2

20 C13, 220 C14, 27 C15, 470 C16, 68 C17, 220
L3, 0.525uH 11t #22 T50-6 or 12t #24 T37-2
L4, 0.475uH 10t #22 T50-6 or 11t #24 T37-2

10 C13, 120 C14, NA C15, 270 C16, 39 C17, 120
L3, 0.270uH 10 turns #24 T25-6
T25s L4, 0.200uH 8 turns #24 T25-6

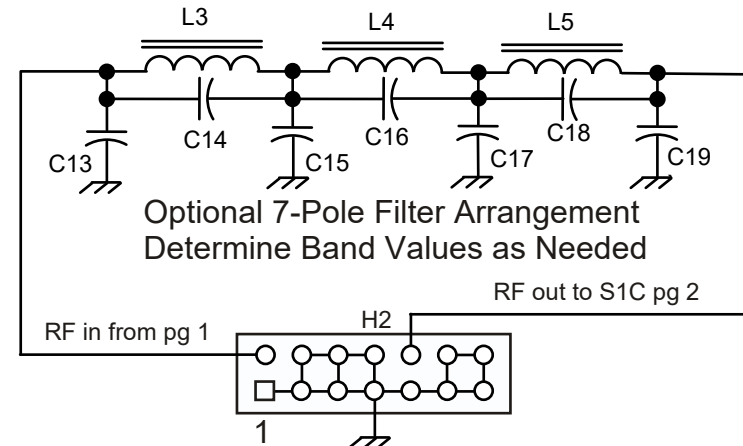

10 C13, 120 C14, NA C15, 270 C16, 39 C17, 120
L3, 0.270uH 9 turns #24 T37-6
T37s L4, 0.200uH 7 turns #24 T37-6